

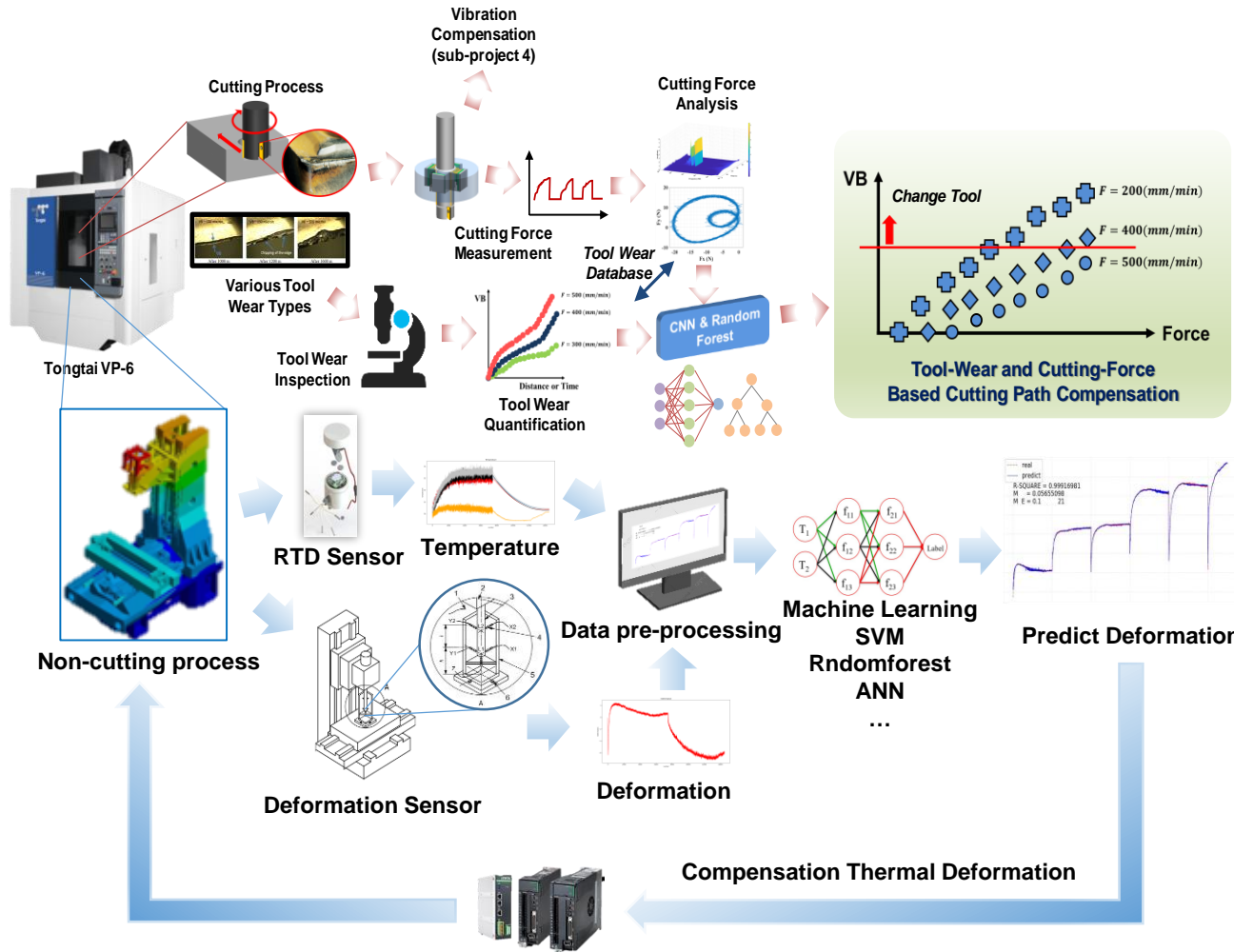

Industrial Sensor Laboratory

Real-time Compensation of Machining Error Using AI



U-tube Coriolis Mass Flow Meter

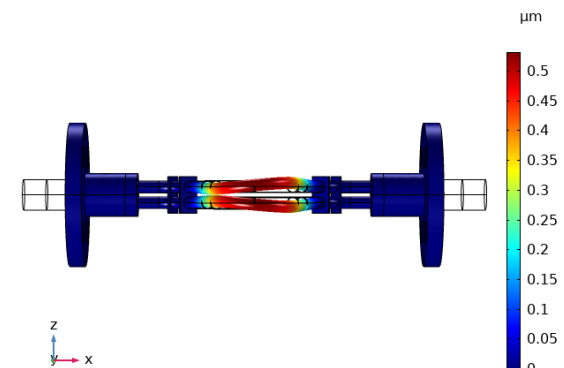
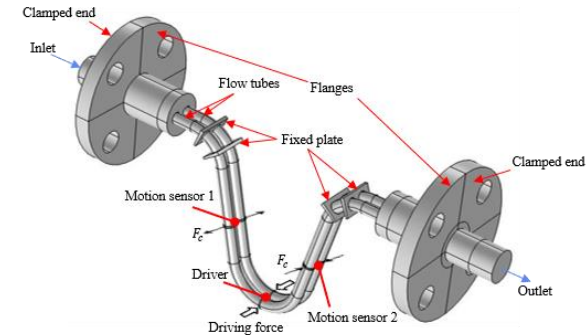

Thermal Deformation Model of CNC Using ML